

Kelvion



Goedhart® air coolers

Goedhart® Abbatoir Units (AU.s)

AIR COOLERS FOR MEAT PROCESSING







**Kelvion –
a tribute to
Lord Kelvin**

**70 branches and
sales partners
worldwide**

**More than 4,000
employees
worldwide**

Lord Kelvin (1824 – 1907) formulated
the laws of thermodynamics

EXPERTS IN HEAT EXCHANGE - SINCE 1920

Welcome to Kelvion. As successor to the GEA Heat Exchangers Group, we continue to break new ground, making discerning customers more successful than ever with our integrated heat exchanger solutions.

Our solutions for your applications:

We offer our customers one of the world's largest product portfolios in the field of heat exchangers. It includes individual solutions for practically all conceivable applications and complex environmental conditions: plate heat exchangers, shell and tube heat exchangers, finned tube heat exchangers, modular cooling tower systems, and refrigeration heat exchangers.

Your markets are our markets, too:

The markets in which you and we together operate are among the most important in the world: energy, the oil and gas industry, the chemical industry, marine applications, food and beverages, climate and environment. We provide every single market segment with solutions of outstanding efficiency, safety, and sustainability.

We are highly committed to earning your trust:

We want to win your trust with everything we do and convince you with the solutions we offer. With this high aim in mind, we invest our extensive know-how, our great precision, and our passion in everything we do: including product development, manufacturing, installation, and after-sales support.

Seeing things from the customer perspective:

Your specific requirements count – and nothing else. Whatever we offer you, it must meet these requirements. Our entire way of thinking and working is geared towards this aim. Our customers truly appreciate this: after all, this is how we make their companies more efficient.

We are at your service.

Kelvion – Experts in Heat Exchange.



GOEDHART® AIR COOLERS



Do not settle for compromise, but go for the best cooling solution to suit your situation. That is the philosophy which Kelvion makes himself hard. Since 1935 we develop, produce and deliver worldwide air coolers, air cooled condensers and composite systems for (semi) industrial applications and various markets. Our products are perfect for projects requiring a technical demand and involving a great deal of flexibility in terms of design, dimensions and accessories. Also our products are suitable for all thinkable cooling system types and methods.

To achieve the most optimal and cost efficient air cooler system we are using three levels of engineering:

- **Commercial products:** standard cooling systems available in different fixed sizes;
- **Customized products:** custom made cooling systems built from standard modules;
- **Designed to order products:** extensive cooling systems and applications developed especially for the niche market.

Extensive theoretical and practical project analysis by our professional sales engineers will determine which configuration, materials, and level of engineering best fit your program requirements. Additionally, you can use the innovative 'Goedhart Product Catalogue (GPC), the digital design program for all Commercial and Customized industrial air coolers and air-cooled condensers.

For what level of engineering you choose; Your are with Goedhart in good hands in the field of refrigeration and freezing. This brochure provides information on the Goedhart® Abattoir Units (AU.s), a Designed to order product.

Do you have any further questions, we are happy to help you personally. We thank you in advance for the interest you have shown in Kelvion and its products.













PRODUCT FAMILY

Goedhart® air coolers and condensers







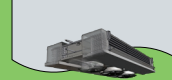

COMMERCIAL PRODUCTS

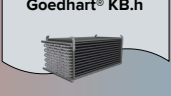
<p>Cu/Al Freons, CO₂, Coolants</p>	<p>Goedhart® FC38S</p> 	<p>Goedhart® FC38L</p> 	<p>Goedhart® FC38D</p> 	<p>Goedhart® PAC</p> 
--	--	--	---	--











CUSTOMIZED PRODUCTS

<p>Cu/Al Freons, CO₂, Coolants</p>	<p>Goedhart® VCI</p> 	<p>Goedhart® VCe</p> 	<p>Goedhart® VNS</p> 	<p>Goedhart® DVS</p> 	<p>Goedhart® BC50 Goedhart® BC50XF</p> 
<p>StSt/Al StSt/StSt NH₃, CO₂, Coolants</p>	<p>Goedhart® VRB Goedhart® VRZ</p> 	<p>Goedhart® VRe</p> 	<p>Goedhart® VRS</p> 	<p>Goedhart® DRS</p> 	<p>Goedhart® BR50 Goedhart® BR50XF</p> 
<p>FeZn NH₃, CO₂, Coolants</p>	<p>Goedhart® ZFB Goedhart® ZFZ</p> 	<p>Goedhart® ZGB Goedhart® ZGZ</p> 	<p>Goedhart® DZS</p> 		



DESIGNED TO ORDER & OEM PRODUCTS

<p>Cu/Al StSt/Al StSt/StSt FeZn</p>	<p>Goedhart® KB.v Goedhart® KB.h</p> 	<p>Goedhart® TN.s Goedhart® TN.p</p> 	<p>Goedhart® PLK.s Goedhart® PLK.p</p> 	<p>Goedhart® AU.s Goedhart® AU.p</p> 
	<p>Goedhart® LLK.s Goedhart® LLK.p</p> 	<p>Goedhart® DL.v Goedhart® DL.h</p> 	<p>Goedhart® SLK</p> 	<p>Goedhart® DU.s Goedhart® DU.p</p> 

APPLICATION DRIVEN DESIGNS

<p>Cu/Al StSt/Al StSt/StSt FeZn</p>	<p>Agricultural</p> 	<p>Fruit & vegetable storages</p> 	<p>Distribution centres</p> 	<p>Meat processing</p> 	<p>Penthouse</p> 
	<p>Test facilities</p> 	<p>Marine sector</p> 	<p>Cooling & freezing tunnels</p> 	<p>Leisure</p> 	<p>High pressure (CO₂)</p> 

AIR COOLED CONDENSERS & DRY COOLERS

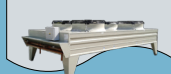
<p>Cu/Al Freons, CO₂, Coolants</p>	<p>Goedhart® KOAL-C</p> 	<p>Goedhart® KOAL-S</p> 	<p>Goedhart® KOAD-S</p> 
<p>StSt/Al NH₃, CO₂, Coolants</p>	<p>Goedhart® INAL-S</p> 		



5



FRESH, CLEAN, SECURE

Before one enjoys a tender and juicy steak or a fillet of chicken, a lot will happen. In order to obtain the best product quality possible, from a good nutrition to a secure healthcare system, transportation and so on. Kelvion products are there as soon as the just slaughtered animals are transported into the chilling or freezing tunnels. Naturally you will find our air coolers in the other areas of the slaughterhouse as well. Slaughterhouse coolers have benefited from huge developments over the last decade. Different material choices have extended the life time cycle, reduced energy costs and are providing higher resistance to the detergents that are used today. The key issue is that the our air coolers are the leaders in achieving low dehumidification and long operating times between defrosting intervals. It results in juicy steaks on one hand and a high ROI on the other.

INNOVATION

We can not emphasize often enough that we can meet our “customized production” philosophy to every customer requirements. Common customer requirements lead to innovation of our products. A good example is the energy efficient Goedhart® VRe range in the stainless steel / aluminium version of our air coolers and air-cooled condensers



Goedhart® AU.s air coolers

BALANCED AIR FLOW



FAN SYSTEM

Because of the very flexible construction of the Goedhart® designed-to-order air coolers, in principle it is possible to deliver with different fans. Depending on the air volume and needed external pressure, we can selected from our standard fan range of Ziehl Abegg (we reserve the right to alter the manufacturer) or we can offer you high pressure fans from different suppliers (preferred supplier NUAIRE) which fits perfectly on the Goedhart® air coolers. Against an extra price stainless steel guards and EC-fans are available, but also a complete stainless steel casing.

Fan execution

The fans meet the ErP2015 directive. The fans have very good aerodynamic features because of the special impeller geometry. This special impeller geometry gives the fan a low noise level and an high efficiency.

SPECIFICATIONS

Fan data Ziehl Abegg

1x230V-AC	: till -25°C environment temperature
3x400V-AC	: till -40°C environment temperature (between -40°C en -50°C environment temperature on request)
1x230V-EC	: till -25°C environment temperature
3x400V-EC	: till -35°C environment temperature
Tension	: 1x230V-50Hz (60Hz on request) : 3x400V-50Hz : 3x400V or 3x460V-60Hz
Protection class	: IP44 / IP54
Color	: RAL9005 (black)
Speed controlling	: 3 phase: 2 speeds by Δ -Y reconnection : frequency controller with all-pole sinus filter : 1 phase : phase-control : transformer

Fan data NUAIRE

- 3x400V-AC : till -50°C environment temperature
- Power supply : 3x400V-50Hz
: 3x380V or 3x460V-60Hz
- Protection class : IP56 / IP66
- Color : Natural
- Speed controlling : 3 phase: 2 speeds by Δ -Y reconnection
: frequency controller with all-pole sinus filter

The motors are standard executed with a thermo contact (TB) and must be connected to prevent motor damages.

The maximum allowable working data in the table and on the name plate of the fans are to operate in an air temperature of +20 °C (air density of $\rho = 1,2 \text{ kg/m}^3$). For air temperatures lower than +20 °C, the current amperage can be calculated by using the diagram multiplication factor, suitable thermal overloads can then be selected. In our Goedhart GPC selection program also the values in the working point are indicated.

SOUND DATA

The mean sound pressure (LpA @ 3m \pm 2 dB (A)) each air cooler is a calculated indication value according to the EN13487 standard parallel pipe. Kelvion uses the fan manufacturer's sound power level (LwA) at the inlet side of the fan. Changes to or by the fan or the product, affect the sound, in these cases, consult the manufacturer for the new indication value. In critical sound requirements, we advise you to consult an expert.

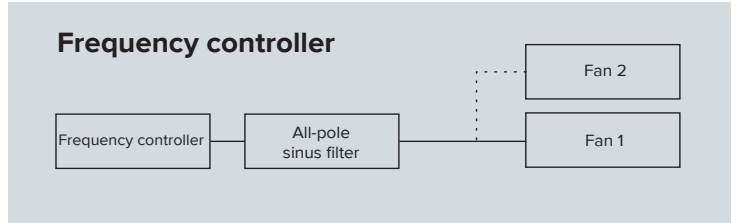
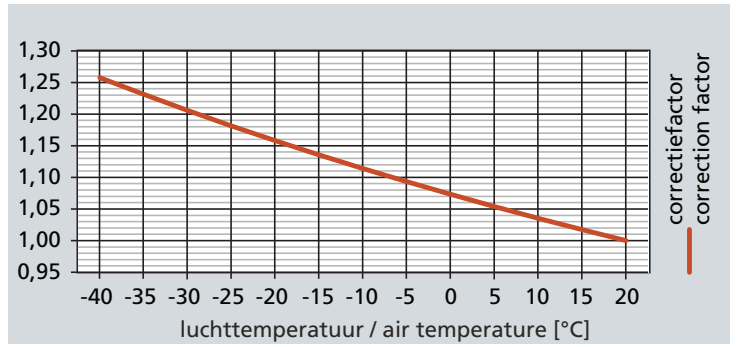



GOEDHART® AU.S / AU.P AIR COOLERS

Abattoir units

The Goedhart® AU air coolers are especially suitable for blast freezing and slaughter house applications. The fans are arranged vertical draw-through. The Goedhart® AU is available with foot mounting (Goedhart® AU.s) or ceiling mounting (Goedhart® AU.p)

Coil block, the heart of a Goedhart® heat exchanger

Robust and reliable, excellent performance through a combination of quality materials, craftmanship and experienced engineering.

Tube configuration

- 50x50 mm straight
- 60x60 mm straight

Fin spacing:

- single fin spacings
- multiple fin spacings

Material combinations:

- 15 mm o.d. copper tubes / aluminium fins
- 15 mm o.d. stainless steel tubes / aluminium fins
- 15 mm o.d. stainless steel tubes and fins
- 22 mm o.d. stainless steel tubes / aluminium fins
- 22 mm o.d. steel tubes and fins / hot dipped galvanized

The Goedhart® AU coil block is standard build from end plates, tubes and fins. Standard refrigerant connections are positioned on the left hand side of the unit when looking with the direction of the airflow. All coolers are pressure tested to 32 bar (lower by cooling mediums) and are supplied with a light over pressure charge. Suitable for NH₃-pumpcirculation (ratio 2/4), CO₂, HFK's and coolants.

Casing

- Construction for floor (AU.s) or ceiling (AU.p) mounting
- Casing material of galvanized sheet steel (not painted)
- An extra wide drip tray to collect all condensation water from the side end plates of the coil.
- The aluminium inner tray is provided with special profiles for optimal conductivity for a hotgas coil or electrical heating elements.
- Stainless steel fasteners.

Goedhart® AU.s / AU.p features

- For slaughter house applications
- Blow-through or draw-through execution possible
- EC fan technology possible
- Suitable for NH₃ pump system, CO₂, HFK's and coolants
- Optimized cooling circuits
- A wide variety of accessories and options available (page. 14)

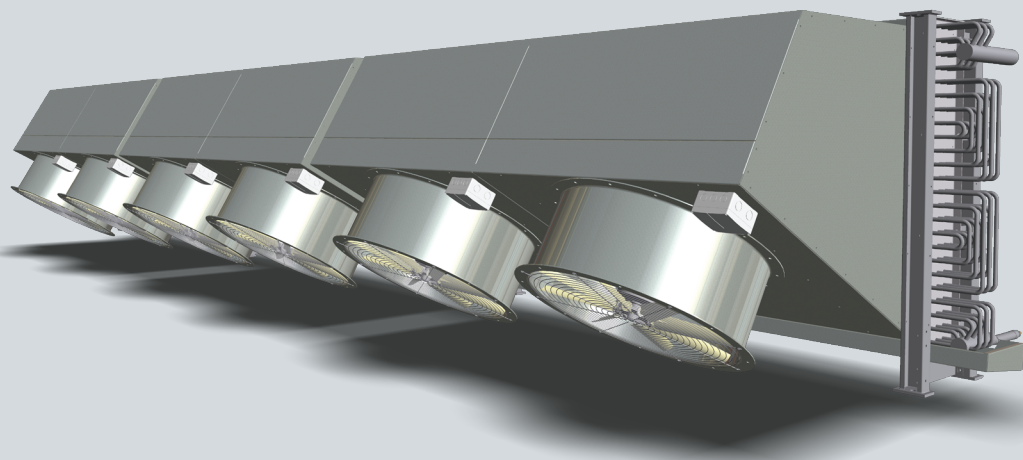
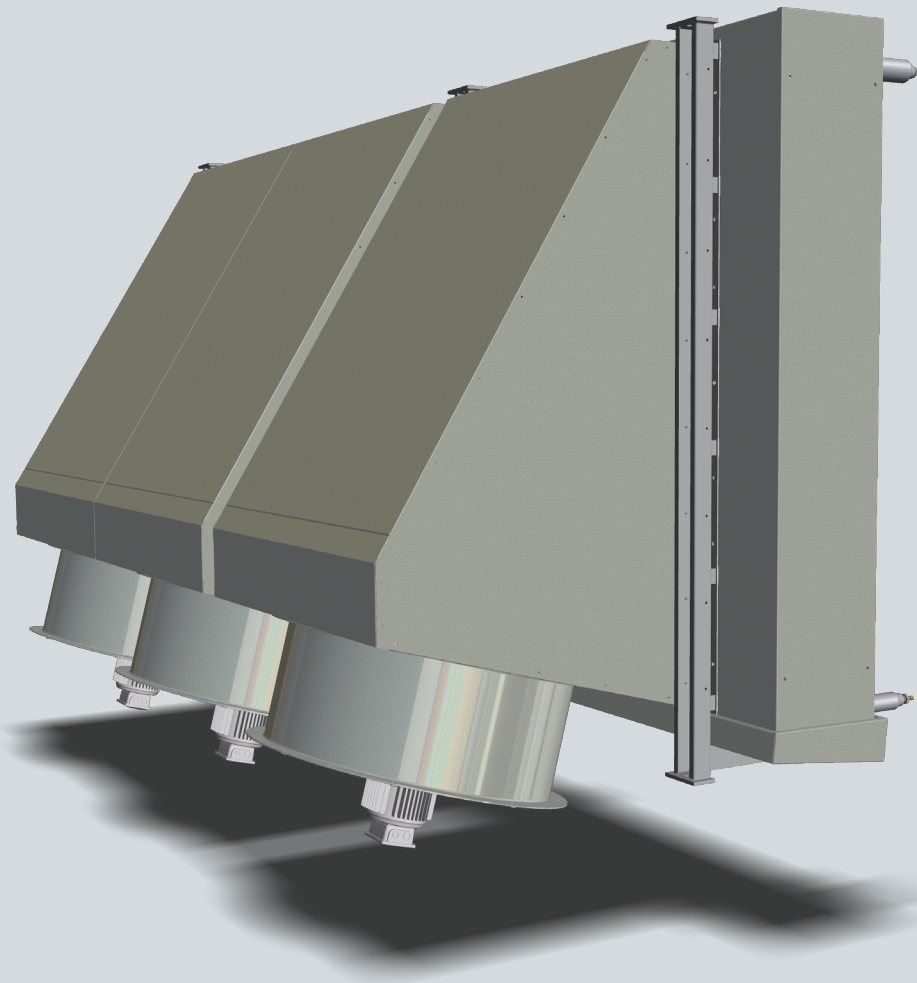

FLEXIBLE SOLUTIONS FOR YOUR APPLICATIONS

Accessoires

	Goedhart® AU.s	Goedhart® AU.p
Hotgas defrost	X	X
Electrical defrost	X	X
Water defrost	X	X
Integrated secundair defrost circuit	X	X
Anti-condensation heating driptray	X	X
Fan heating	X	X
Hinged drip tray		X
Insulated drip tray	X	X
Polyester drip tray	X	X

Options

Insulation disks	X	X
Suction hoods over the fan	X	X
Suction hood fin side *	X	X
Fans 60Hz	X	X
Fans EC	X	X
Coolants	X	X
Pump system	X	X
CO ₂	X	X
Other casing material	X	X
Other fin spacings	X	X
Fins Almg	X	X
Fins Goldlack	X	X



DEFROST SYSTEMS

For room temperatures where ice-build up can be expected and where the coil can not be defrosted by the room air, an defrost system is available.

Electrical defrost

On request Goedhart® Designed-to-order air coolers can be provided with electrical defrost. A distinction can be made here between heavy defrost loads for low temperatures and light defrost load for higher temperatures (room temperature approximately 0 °C). The stainless steel heating elements are fitted in the coil block within aluminium tubes, which forms a highly conductive medium between the heaters and the fins. In the drip tray heater elements are fitted to the underside of the aluminium inner tray. The elements are rated for 220/240 V and are connected (IP55) for 380/415 V (with neutral) supply. The heater elements in the coil block are removable from the bend side, whilst the tray heater elements can be removed once the outer tray has been removed.

The exact number of elements and electrical power for light and heavy defrost each air cooler depends on the size of coil block. On every quotation the power is mentioned.

Hot gas defrost

The coil block is as standard suited for hot gas defrost (hot gas supply through the suction header). Against an extra price the drip tray can be provided with a copper hot gas spiral. This is enclosed in aluminium profiles that are rigidly secured to the under side of the aluminium inner drip tray. As a result, a very good heat transfer is realized. As with electric defrost a distinction is made with light defrost (room temperature around 0 °C) and heavy defrost.

Water defrost

On top of the coil block a removable water defrost tray is mounted. The height of the water defrost tray is 80 mm, which increases the total height of the air cooler. The standard discharge head of the water in the water defrost tray is 25 mm, the maximum speed in the water supply line is 5m / sec. For an optimal functioning of the water defrost, the temperature of the defrost water must be between + 15 ° C and at + 30 ° C. The water defrost tray is executed with handles, easy for disassemble and cleaning.

FAN HEATING

The fan heating prevents ice build-up between the fan impeller and fan bellmouth during the defrost cycle. This prevents damaging of the fan.

We advise to use fan heating as an option on your air cooler when the room temperature $< -10^{\circ}\text{C}$

Delivery

- Is mounted and connected to a junction box
- Can also be retrofitted

fan diameter	Power at 230V
mm	kW
500	0,31
560	0,48
630	0,48
710	0,48
800	0,63
900	0,63
1000	0,63
1120	0,78
1250	0,78

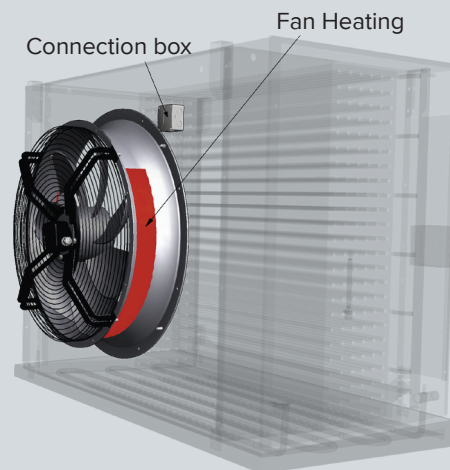

SUCTION HOOD

(Draw-through air coolers)

The suction hood is applied when used for freezing applications from -18°C . It supports the alternate defrost for the air cooler in the freezing room. The suction hood is carried out with 13 mm insulation.

- The suction hood is equal to the casing material of the air cooler.
- Suction hood is supplied separately and is easy to assemble

Advantages

The suction hood prevents draw in the air cooler during defrosting. The heat remains on this way in the cooler and that means:

- Shorten the defrosting time by over 50%
- Significant energy savings
- No frost formation on the ceiling of the room and to the products with minimum vapor formation

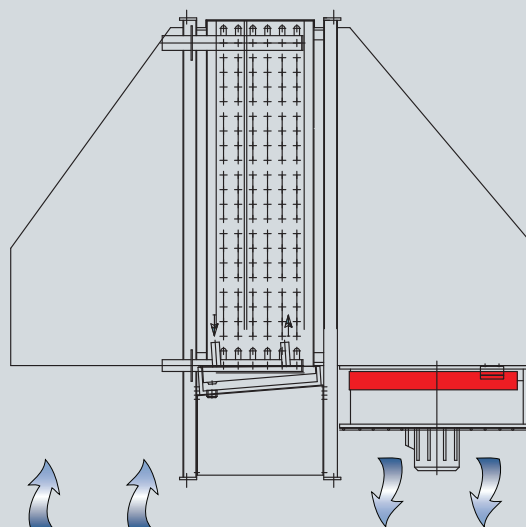



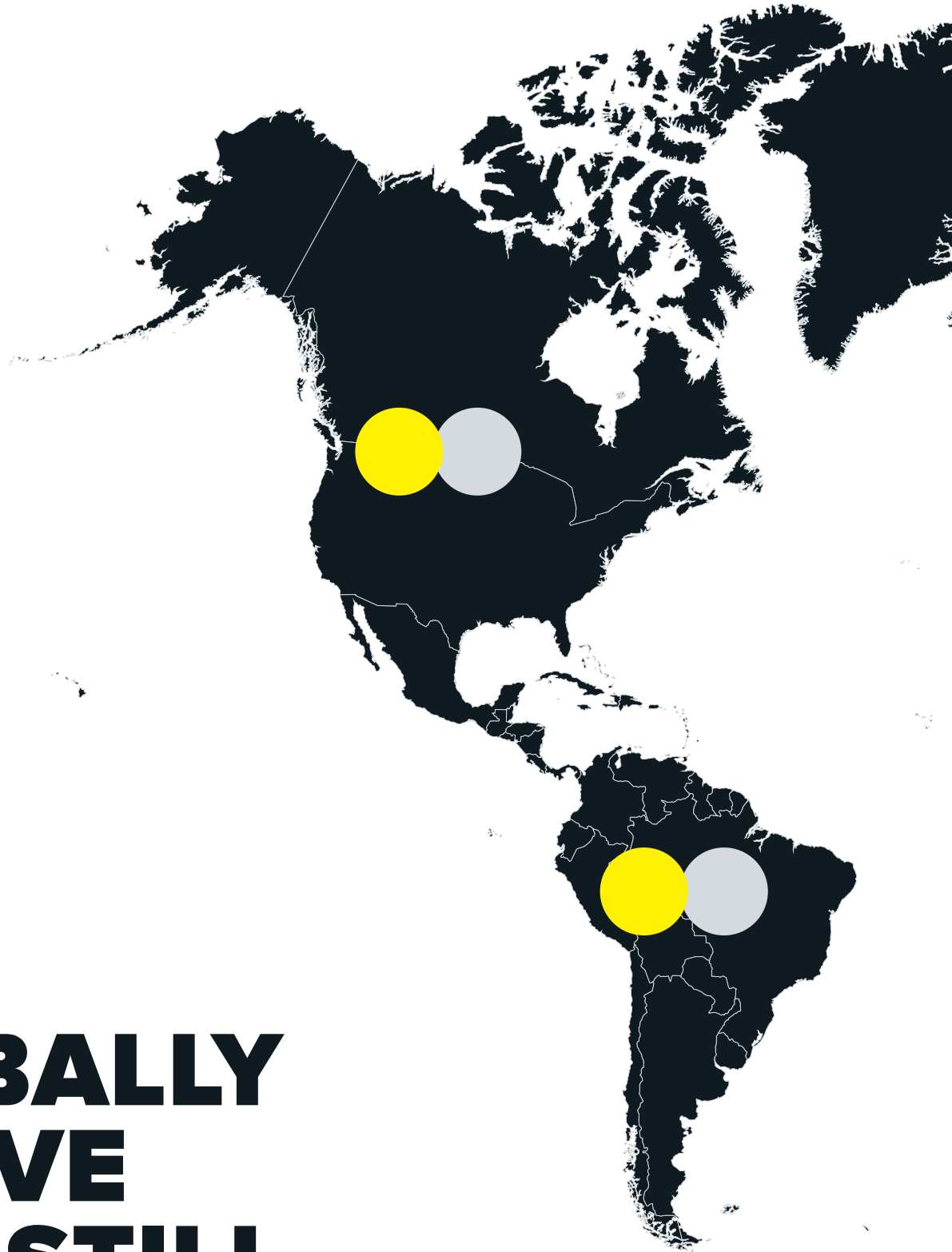

GLOBALLY ACTIVE AND STILL CLOSE BY

No matter where your market is, regardless of country, we are never far away. We are always happy to answer any questions you may have and meet your requirements. Even the largest, most successful project begins with an initial, profitable conversation. We look forward to hearing from you.

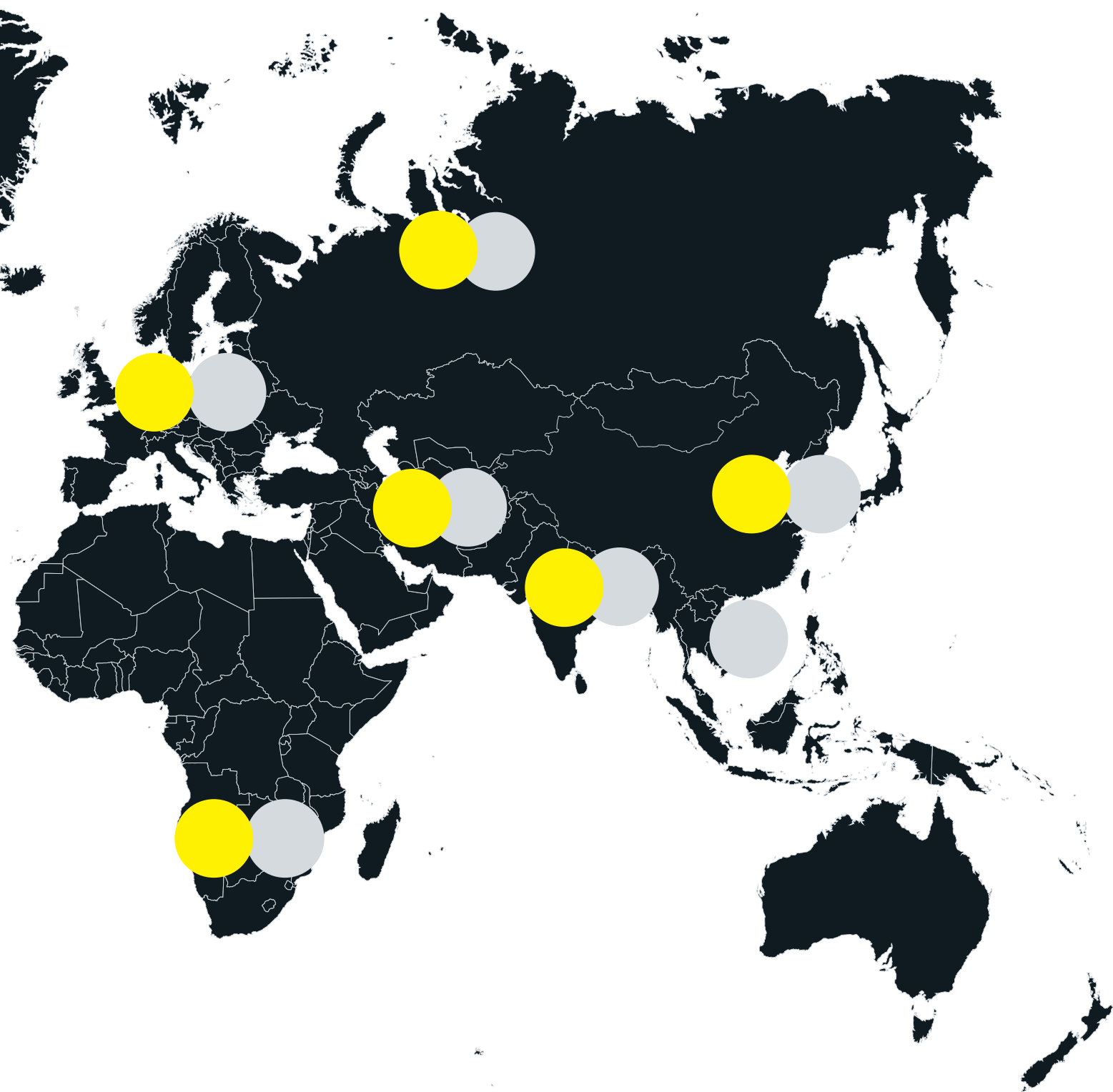

● Global production footprint

● Global sales and service



Just scan this QR code with your smartphone or visit our website at: www.kelvion.com – there you will find a highly competent contact in your immediate vicinity.

www.kelvion.com